

Stahlbearbeitung



VHM-Schmiernutenfräser

für Schmiernuten Form C DIN/ISO12128
(früher DIN1591)

*Solid carbide oil groove mill
for oil grooves form C DIN/ISO12128 (DIN1591)*

*Frese in metallo duro
per scanalatura per lubrificazione
per scanalature forma C DIN/ISO12128 (DIN1591)*



Qualitätsmanagement nach ISO 9001:2000
Quality management system in accordance
with the ISO 9001:2000 standard



Schiedlberger Straße 10
A 4522 Sierning
T +43 (0) 72 59 / 23 47-0
F +43 (0) 72 59 / 31 62
office@rabensteiner.com
www.rabensteiner.com

RABENSTEINER
PRÄZISIONSWERKZEUGE

VHM-Schmiernutenfräser

für Schmiernuten Form C DIN/ISO12128 (früher DIN 1591)

Solid carbide oil groove mill
for oil grooves form C DIN/ISO12128 (DIN1591)

Frese in metallo duro per scanalatura per lubrificazione
per scanalature forma C DIN/ISO12128 (DIN1591)

4150 Best.Nr. order no. codice



VHM
Submicron



30°λ

EM

DIN 6535A



Z2

Stahlguss
Cast steel
Acciaio ad alta resistenza

Stahl
Steel
Acciaio

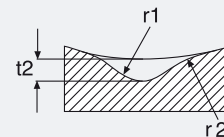
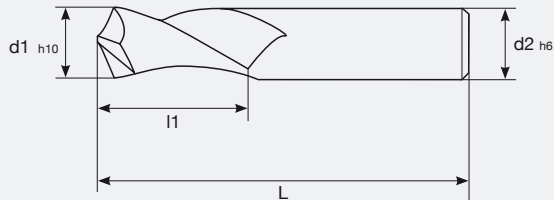

Bei der Bestellung bitte Bestellnummer angeben: Best.Nr. z.B. für $\varnothing 12 \times 16 \times L 73\text{mm}$ = 4150-1200
Please indicate order number for $\varnothing 12 \times 16 \times L 73\text{mm}$ = 4150-1200
Preghiamo d'indicare il numero d'ordine - $\varnothing 12 \times 16 \times L 73\text{mm}$ = 4150-1200

Abmessungen Dimensions Dimensioni

Bestellnummer order no. codice	$\varnothing d1 - h10$ mm	r1 mm	r2 mm	t2 mm	$\varnothing d2 - h6$ mm	L mm	l1 mm	z
4150-0600	6	1,5	3	0,8	6	52	8	2
4150-0800	8	2	4,5	1,0	8	61	11	2
4150-1000	10	2,5	6	1,2	10	63	13	2
4150-1200	12	3	9	1,6	12	73	16	2
4150-1600	16	4	12	2,0	16	79	19	2
4150-2000	20	5	15	2,5	20	82	22	2
4150-2500	25	7	21	3,2	25	104	26	2

Zwischenabmessungen können auf Wunsch kurzfristig geliefert werden
Upon request intermediate dimensions can be supplied at short notice
Dimensioni intermedie possono essere fornite a richiesta a breve termine

Sonderwerkzeug special tool utensili speciale

Anfrage request richiesta **Bestellung** order ordine

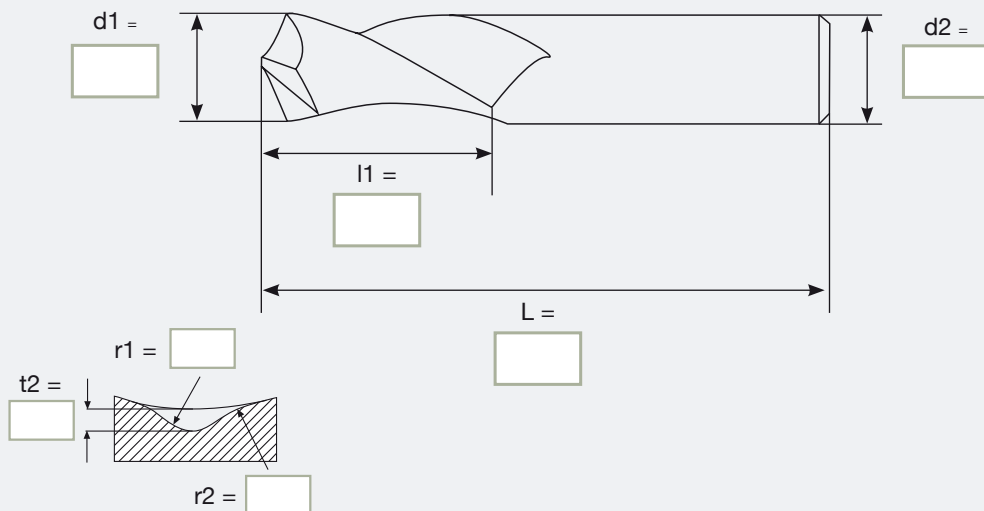

Sonderwerkzeug special tool utensili speciale

Zu bearbeitender Werkstoff material to be cut materiale da lavorare

.....

Schaftform shank design forma di gambo

Stückzahl pieces pezzi

Form A Form B

.....

Beschichtung coating rivestimento

keine without senza

.....

Adresse adress indirizzo

Firma:

Name:

Bezeichnung:

Abteilung:

Strasse:

Telefon:

PLZ/Ort:

e-mail:

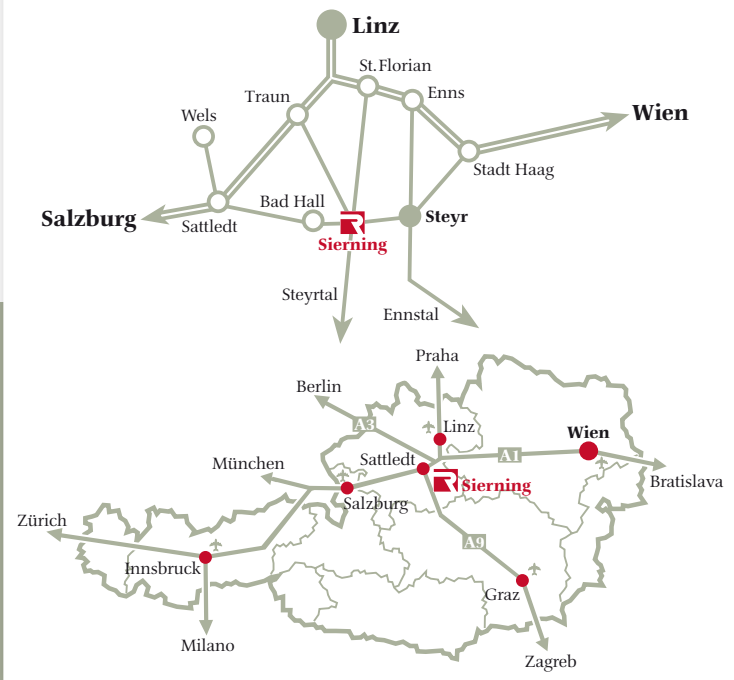

HQ PRECISION TOOLS

Unsere Vertretung

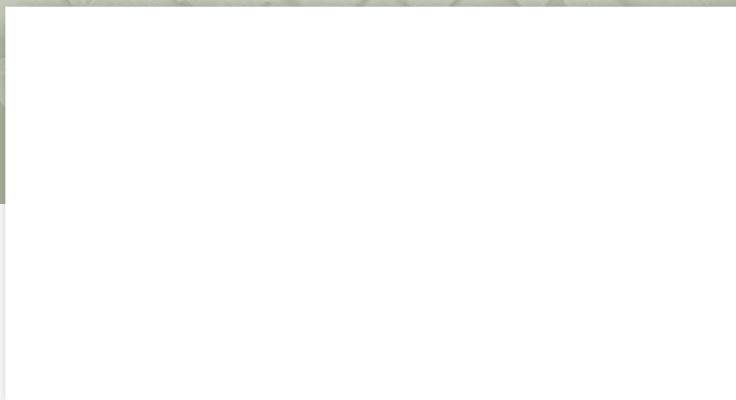

Rabensteiner
 Produktions- und Vertriebs GmbH
 Schiedlberger Straße 10
 A 4522 Sierning, Austria
T +43 (0) 72 59 / 23 47-0
F +43 (0) 72 59 / 31 62
 office@rabensteiner.com
 www.rabensteiner.com



RABENSTEINER
 PRÄZISIONSWERKZEUGE